

Mounting instructions

Air-termination rod fastening for metal roofs F-FIX-MD

Air-termination rod fastening for metal roofs F-FIX-MD

Mounting instructions

Table of contents

1	About these instructions	4
1.1	Target group	4
1.2	Relevance of these instructions	4
1.3	Types of warning information	4
1.4	Basic standards and regulations	4
1.5	Applicable documents	5
2	Intended use	5
3	Safety	5
3.1	General safety information	5
3.2	Personal protective equipment	6
4	Necessary tools	6
5	Product description	6
5.1	Product overview	7
5.2	Accessories	8
6	Planning an installation	9
6.1	Determining the wind load	9
7	Mounting the air-termination rod fastening	10
8	Attaching the air-termination rod	12
9	Arresting the air-termination rod	14
10	Providing additional support for the air-termination rod	15
10.1	Determining the type of support	15
10.2	Support components	17
10.3	Support angle and length	18
10.4	Mounting the support	19
11	Maintaining the air-termination rod fastening	20
12	Disassembling the air-termination rod fastening	20
13	Disposing of the air-termination rod fastening	20
14	Technical data	20

1 About these instructions

1.1 Target group

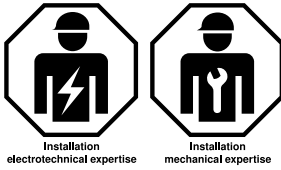

These mounting instructions are intended for specialists who are qualified to erect lightning protection systems in accordance with VDE 0185-305 (IEC 62305), e.g. lightning protection specialists. These specialists must know the lightning protection standards applicable at the mounting location, as well as the generally recognised rules of technology.

1.2 Relevance of these instructions

These instructions are based on the standards valid at the time of compilation (February 2026).



Please read the instructions carefully before commencing mounting. We will not accept any warranty claims for damage and liability caused through non-observance of these instructions.

Any images are intended merely as examples. Mounting results may look different.

All the documents supplied with the product must be stored in an easily accessible location, so that they are available when information is required. (Only for printed instructions)

In these instructions, cables and lines are referred to simply as cables.

To find out more about planning and mounting the product, we recommend a comprehensive training course.

1.3 Types of warning information



Type of risk!

Shows a risky situation. If the warning information is not observed, then serious or fatal injuries may occur.

Note!

Indicates important information or assistance.

1.4 Basic standards and regulations

- DIN EN 62561-1 ED 2 (IEC 62561-1, VDE 0185-561-1):
Lightning protection system components – Part 1: Requirements for connection components
- DIN EN 62305-3 ED 2 (IEC 62305-3, VDE 0185-305-3):
Protection against lightning – Part 3: Protection of structural facilities and persons

- DIN EN 1991-1-4: 2010-12, Eurocode 1: Effects on structures – Parts 1–4: General effects – wind loads
- DIN EN 1991-1-4/NA: 2024-08, Eurocode 1: Effects on structures – Parts 1–4: General effects – wind loads

1.5 Applicable documents

Lightning protection components are not subject to an EU directive. Instead, OBO makes the provider's declarations of conformity available for the appropriate components of the lightning protection systems. These declarations of conformity certify the agreement with the named standards and stored documents, but do not, however, contain any guarantee of properties.

2 Intended use

The air-termination rod fastening is used to mount air-termination rods (\varnothing 16 mm) on metal roofs (F-FIX-MD) or Kalzip metal roofs (F-FIX-MD+) with a slope of up to 38°.

The air-termination rod fastening is not designed for any use other than that described here. If the air-termination rod fastening is used for another purpose, then this shall render all liability, warranty and damage claims null and void.

3 Safety

3.1 General safety information

Observe the following general safety information:

- If there is a lightning strike, lethal currents can flow through the lightning protection system. Never work on the elements of the lightning protection system during a thunderstorm or if there is the risk of one.
- Before mounting, calculate and dimension the system according to local circumstances according to Eurocode 1: DIN EN 1991-1-4.
- Take the approved roof loads at the mounting location into account and, if necessary, agree with the building constructor.
- Check the air-termination rod fastening, air-termination rod and accessories for proper condition. Do not mount incomplete or damaged items.

3.2 Personal protective equipment



List of personal protective equipment to be used:

The production method means that metallic objects may have areas with sharp edges. Wear suitable protective gloves to avoid cutting injuries.

4 Necessary tools

List of tools to be used:

- Open-end wrench, WAF: 10, 17 and 19
- Torque spanner

5 Product description

The air-termination rod fastening can be mounted on metal roofs with a slope of up to 38°. Air-termination rods with a diameter of 16 mm can be fastened at an angle of inclination of up to 38°.

The material is resistant to frost, weathering and UV.

The air-termination rod fastening is suitable for mounting air-termination rods at wind loads according to Eurocode 1: DIN EN 1991-1-4.

The air-termination rod fastening is available either without metal roof fastening materials (F-FIX-MD) or with folding clamps for Kalzip roof profiles (F-FIX-MD+).

The air-termination rod is not contained in the scope of delivery.

5.1 Product overview

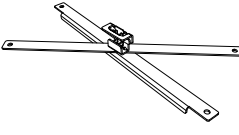
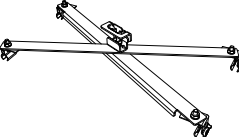
Article	Item no.	Type	Designation	Use
	5403336	F-FIX-MD	Air-termination rod fastening for metal roof	Can be extended with adequate metal roof fastening materials (e.g. folding clamps or bridging straps)
	5403337	F-FIX-MD+	Air-termination rod fastening for Kalzip metal roof	With folding clamps for Kalzip roof profile

Tab. 1: Air-termination rod fastenings

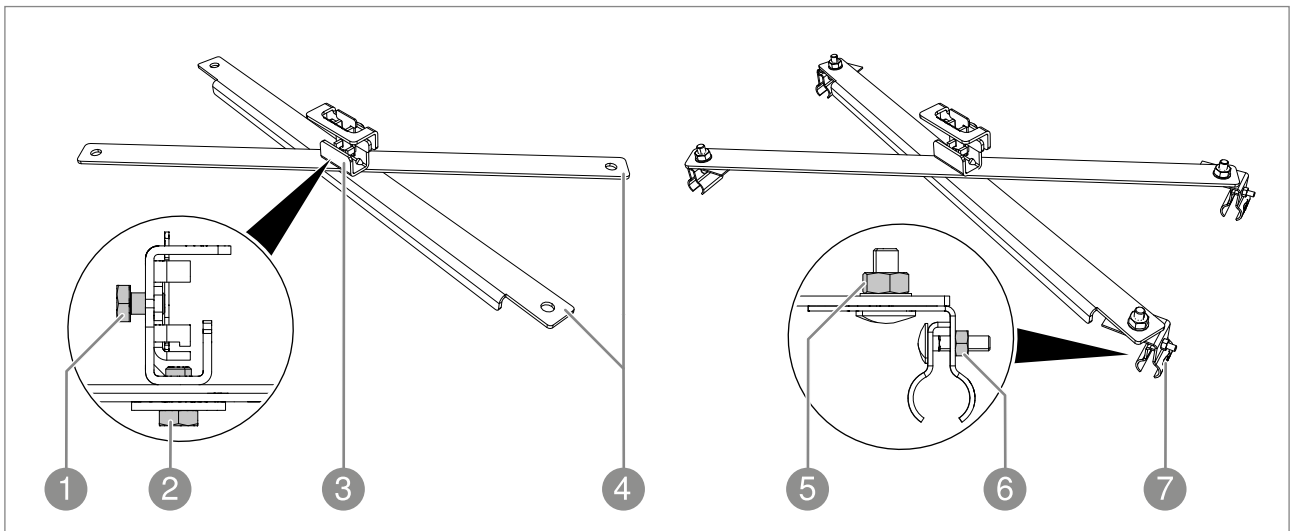

Fig. 1: Product overview

- ① 1 Hexagonal bolt M10x16
- ② 1 Hexagonal bolt M12x20
- ③ 1 Clamping element
- ④ 1 Strut frame
- ⑤ 1 Hexagonal nut M10
- ⑥ 1 Hexagonal nut M6
- ⑦ 1 Folding clamp (Kalzip)

5.2 Accessories

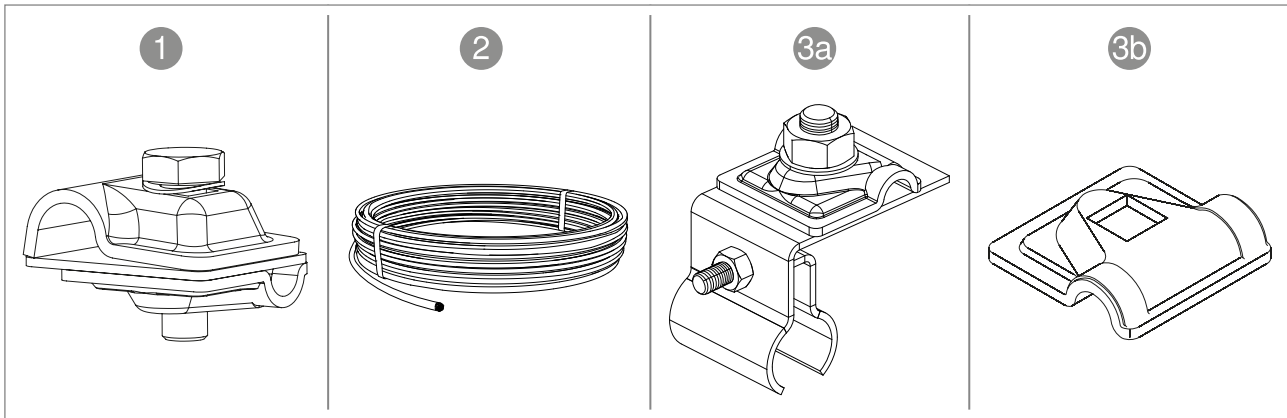

Fig. 2: Accessories

Figure no.	Item no.	Designation	Type	Length	Diameter/hole	Material	Use
1	5311590	Quick connector	249 8-10x16 VA	40 x 50 mm	M10	VA	Fastening the support to the air-termination rod
2	5021235	Round conductor	RD 8-V2A	125 m	RD 8	VA	Conductor, supporting element
	5021227	Round conductor	RD 10-V2A	50 m	RD 10	VA	
	5021239	Round conductor	RD 10-V2A	80 m	RD 10	VA	
	5021644	Round conductor	RD 8-V4A	125 m	RD 8	V4A	
	5021640	Round conductor	RD 10-V4A 20	20 m	RD 10	V4A	
	5021642	Round conductor	RD 10-V4A	50 m	RD 10	V4A	
	5021647	Round conductor	RD 10-V4A	80 m	RD 10	V4A	
3a	5317502	Folding clamp	RSF 249 8-10 VA	67 x 38 mm	M10	VA	When using F-FIX-MD+: Fastening of the support to Kalzip metal roof
3b	5311554	Quick connector, cover	249 8-10 VA-OT	40 x 40 mm	for M10	V2A	When using F-FIX-MD: Fastening of the support to metal roof in combination with metal roof fastening materials

Tab. 2: Accessories

6 Planning an installation

When planning an air-termination system, take the following planning steps into account:

- For the erection of the air-termination rods, determine the appropriate wind load according to Eurocode 1: DIN EN 1991-1-4.
- Depending on the lightning protection class, determine the protection area, the required height and the arrangement of the air-termination rods, according to DIN EN 62305-3 (IEC 62305-3, VDE 0185-305-3).
- Calculate the necessary separation distance according to DIN EN 62305-3 (IEC 62305-3, VDE 0185-305-3).

Note! *You can find detailed planning aids on lightning and surge protection systems in the OBO lightning protection guide.*

6.1 Determining the wind load

To determine the wind load, the following factors must be taken into account, in accordance with Eurocode 1: DIN EN 1991-1-4:

1. Determining the wind load zone

The first factor that needs to be known when determining the wind load is the wind load zone in which the object is located.

2. Determining the terrain category (TC)

Terrain-specific loads and dynamic pressures constitute the second factor in determining wind loads.

3. Determining the wind load

The wind load can be determined based on the wind load zone and terrain category. The wind load must be determined at the project location.

7 Mounting the air-termination rod fastening



Lack of protective function!

Attached to the wrong roof profile, the air-termination rod fastening F-FIX-MD+ cannot ensure the required stability and discharge capacity. The folding clamps of air-termination rod fastening F-FIX-MD+ may only be mounted on the round standing seam edges of Kalzip metal roofs.

Observe the following information:

- On the strut frame of the air-termination rod fastening F-FIX-MD, metal roof fastening materials must be mounted to each strut end with a hexagonal nut M10 to mechanically stabilise the air-termination rod. Select the metal roof fastening materials according to the properties of the respective metal roof.
- In these instructions, mounting is shown using the air-termination rod fastening F-FIX-MD+ with folding clamps already mounted as an example. To mount the air-termination rod fastening F-FIX-MD, the same procedure applies after attaching the metal roof fastening materials.

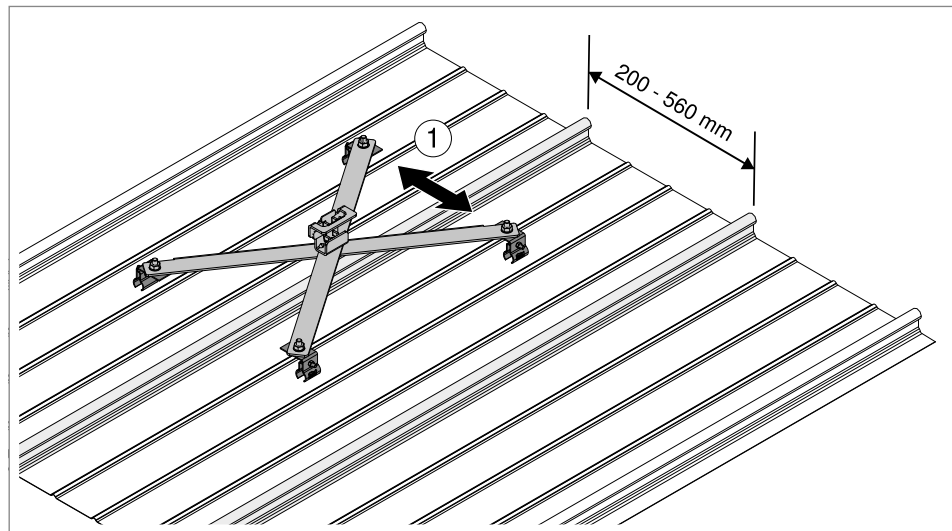

Fig. 3: Mounting the strut frame

1. Adjust the strut frame to the seam spacing of the metal roof.

Note!

The air-termination rod fastening can be mounted on metal roofs with a roof profile that has a seam spacing of 200–560 mm. Seam spacings on Kalzip metal roofs, however, measure a maximum of 537 mm.

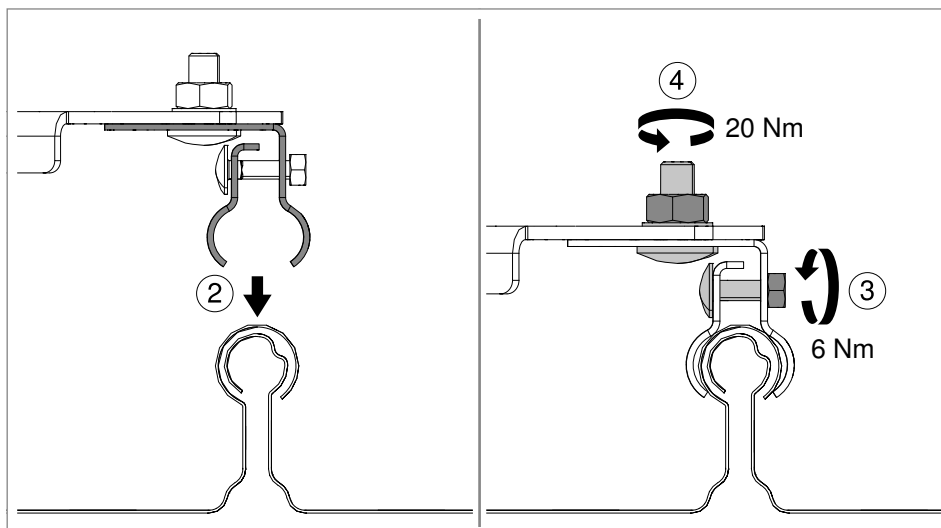

Fig. 4: Fastening the clamps

2. Place all four folding clamps on the seams of the metal roof.
3. Tighten the hexagonal nuts M6 on the folding clamps to fasten the folding clamps on the seams of the metal roof.

Note!

The type of fastening for air-termination rod fastening F-FIX-MD depends on the selected metal roof fastening materials.

4. Tighten the hexagonal nut M10 above the seam to secure the position of the strut frame.

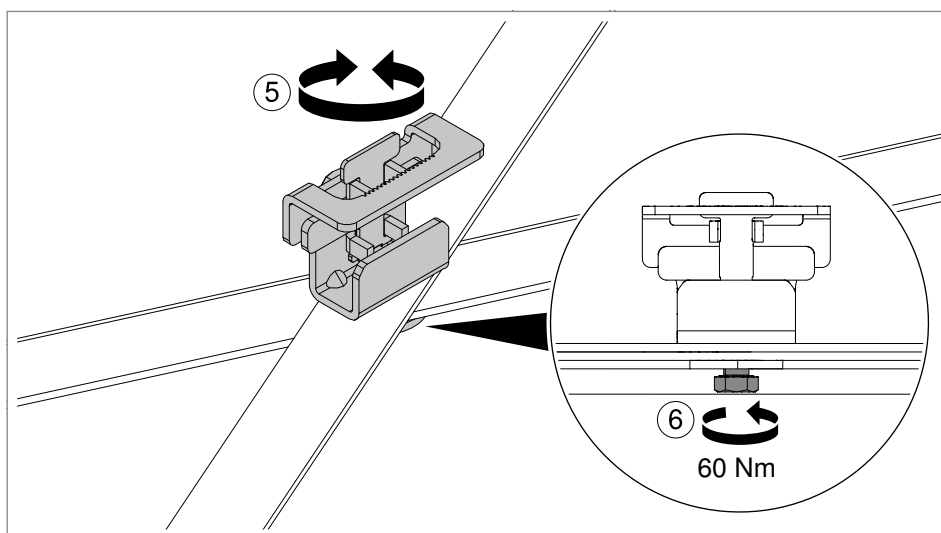

Fig. 5: Aligning the clamping element

5. The clamping element can be rotated 360°. Align the clamping element as needed.
6. Tighten the hexagonal bolt M12x20 under the clamping element using a torque spanner to secure the position of the clamping element.

8 Attaching the air-termination rod

Air-termination rods with a diameter of 16 mm and a total length of up to 4 m can be attached with the air-termination rod fastening.

Air-termination rods with a length exceeding 2 m must be supported with an additional mechanical fastening depending on the wind load determined (see chapter “10 Providing additional support for the air-termination rod” on page 15).

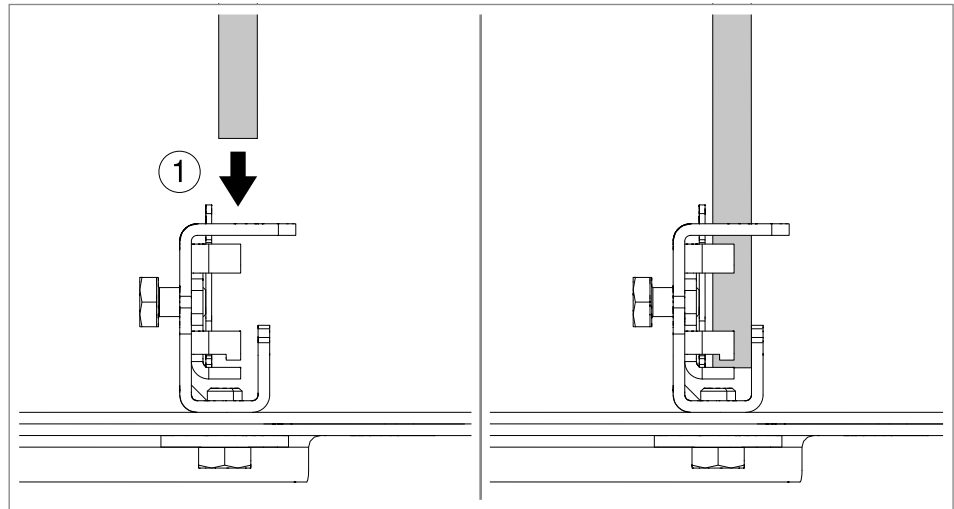

Fig. 6: Inserting the air-termination rod

1. Insert the air-termination rod into the clamping element.



Reduced stability!

If the air-termination rod is not in the clamping element completely, the air-termination rod can come loose again and lose its protective function. Push the air-termination rod completely into the air-termination rod holder.

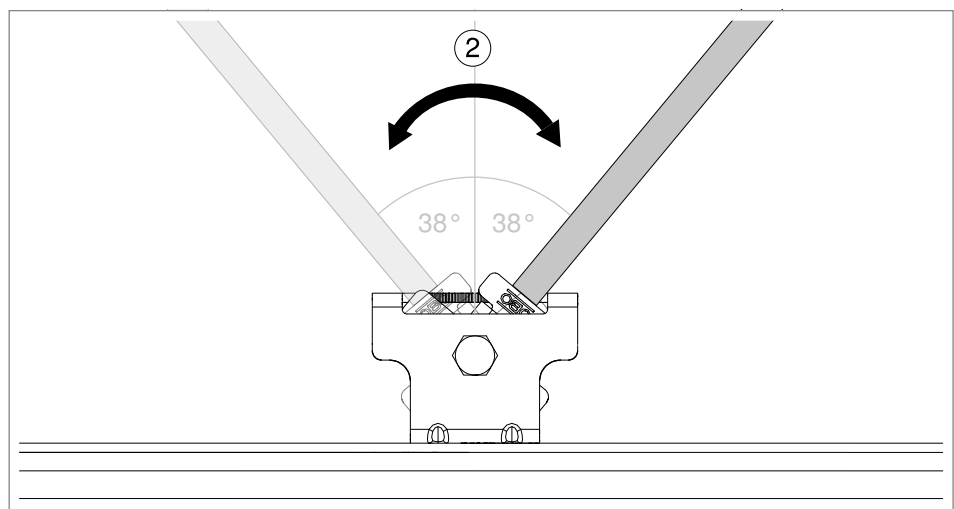

Fig. 7: Adjusting the angle of the air-termination rod

2. Adjust the angle of inclination of the air-termination rod (max. 38° possible in both directions).

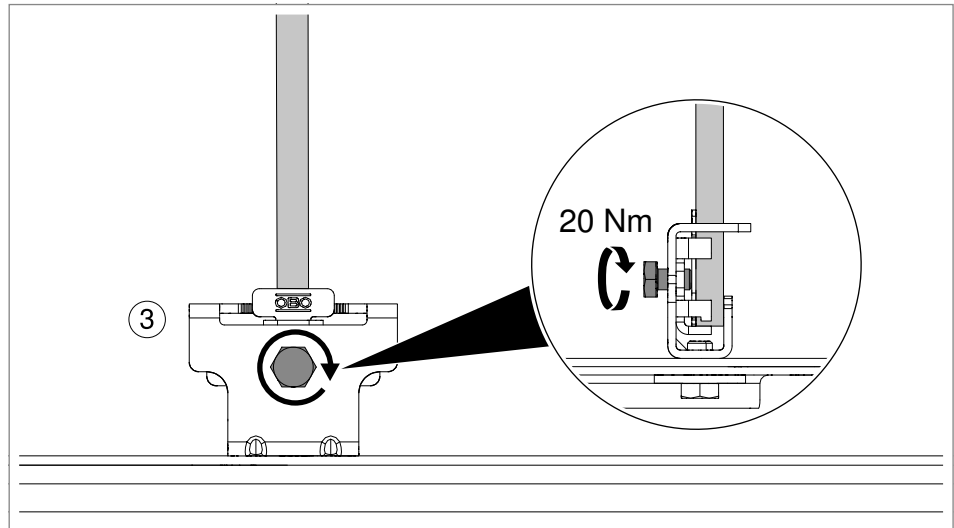

Fig. 8: Securing the position

3. Tighten the hexagonal bolt M10x16 on the side of the clamping element, to secure the position of the air-termination rod.

9 Arresting the air-termination rod

If the metal roof is capable of carrying lightning current (according to DIN VDE 0185-305-3, Supplement 4) and is integrated into the external lightning protection (e.g. via a down conductor cable to a metal roof, metal facade or eaves), no additional down conductor is required, as the air-termination rod is conductively connected to the metal roof via the strut frame and the four folding clamps.

If the lightning current carrying capacity of the metal roof (according to DIN VDE 0185-305-3, Supplement 4) cannot be provided, the air-termination rod must be integrated into the external lightning protection with a separate down conductor.

Note!

Only if the round conductor indicated in chapter "5.2 Accessories" and a quick connector 249 8-10x16 VA are used for the down conductor may the air-termination rod fastening be used for lightning currents H to 100 kA (10/350) in accordance with DIN EN 62561-1.

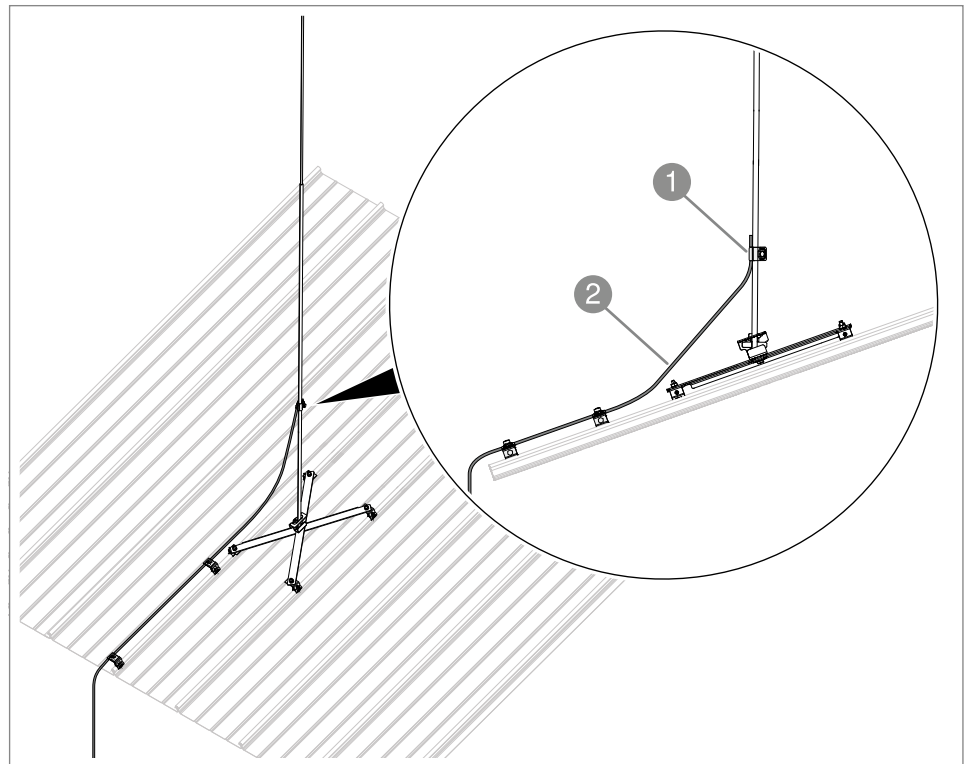

Fig. 9: Attaching the down conductor

1. Fasten round conductor ② to the air-termination rod with quick connector ①.
2. Lead the round conductor ② to the roof edge with suitable clips.
3. Connect the round conductor ② to the equipotential bonding of the construction system.

10 Providing additional support for the air-termination rod

The air-termination rod may have to be provided with additional support following mounting depending on the wind load and the air-termination rod length.

10.1 Determining the type of support

Depending on the wind load, the air-termination rod will need no support at all, or support on one or two sides.

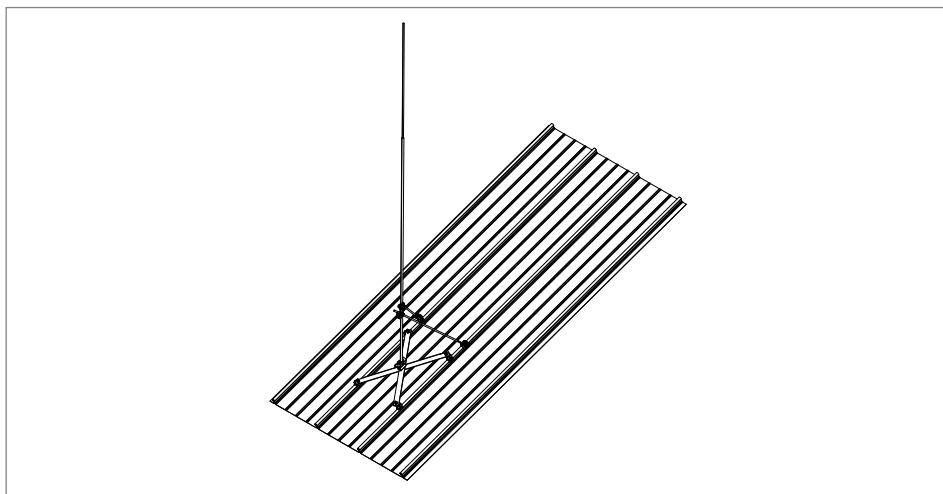

Fig. 10: Support on one side

Note!

Support on one side can be attached above (see Fig. 10) or below the air-termination rod fastening. Both variants of one-sided support provide the same support.

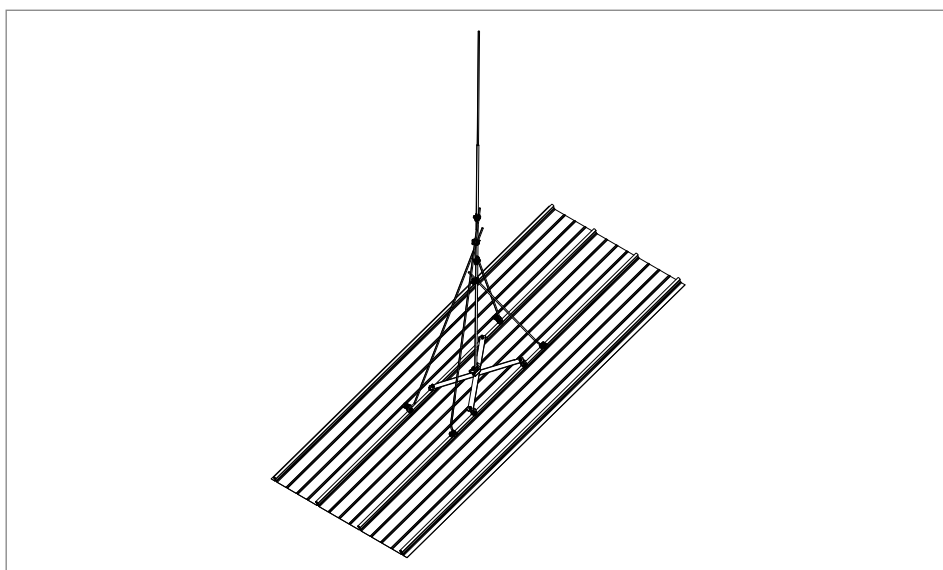

Fig. 11: Support on two sides

Providing additional support for the air-termination rod

In the following table, you can take the wind load calculated in chapter 6.1 to determine whether the air-termination rod length requires no support, support on one side or support on two sides:

Wind load \ Total length of the air-termination rod	1.5 m	2 m	2.25 m	2.5 m	2.75 m	3 m	3.25 m	3.5 m	3.75 m	4 m
≤108 km/h	-	-	-	-	-	-	-	-	1	1
109–117 km/h	-	-	-	-	-	-	-	1	1	2
118–130 km/h	-	-	-	-	-	-	1	1	2	2
131–140 km/h	-	-	-	-	-	1	1	2	2	2
141–157 km/h	-	-	-	-	1	1	2	2	2	2
158–176 km/h	-	-	-	1	1	2	2	2	2	2
177–200 km/h	-	-	1	1	2	2	2	2	2	2
201–275 km/h	-	1	1	2	2	2	2	2	2	2

Tab. 3: Determining the support

10.2 Support components

Note! You will find more exact information on the components of the support in the chapter "5.2 Accessories" on page 8.

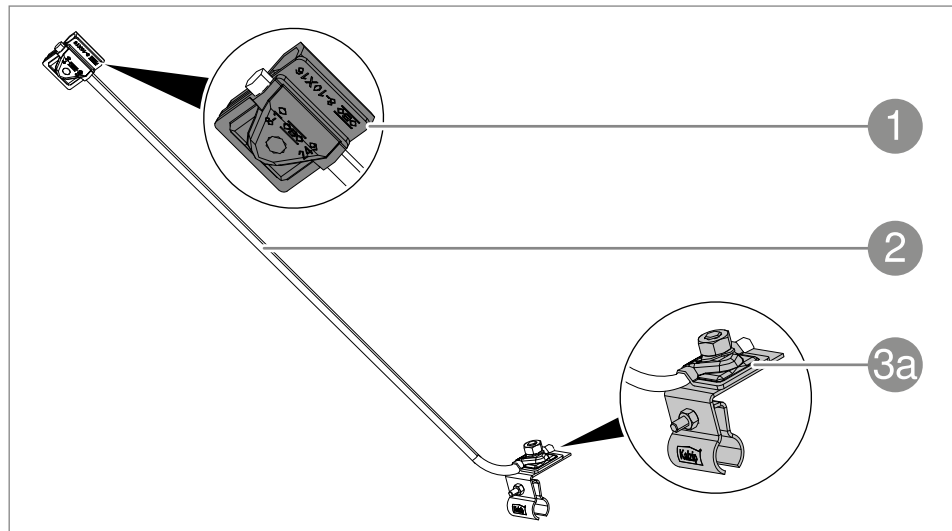

Fig. 12: Support

Fastening of the support depends on the properties of the respective metal roof (3a / 3b).

The support consists of:

- 1 Quick connector
- 2 Round conductor
- 3a Kalzip metal roof: folding clamp
- 3b Other metal roof: Quick connector cover in combination with metal roof fastening materials

Note! Metal roof fastening materials must match the properties of the respective metal roof and be able to accept an M10 screw.

10.3 Support angle and length

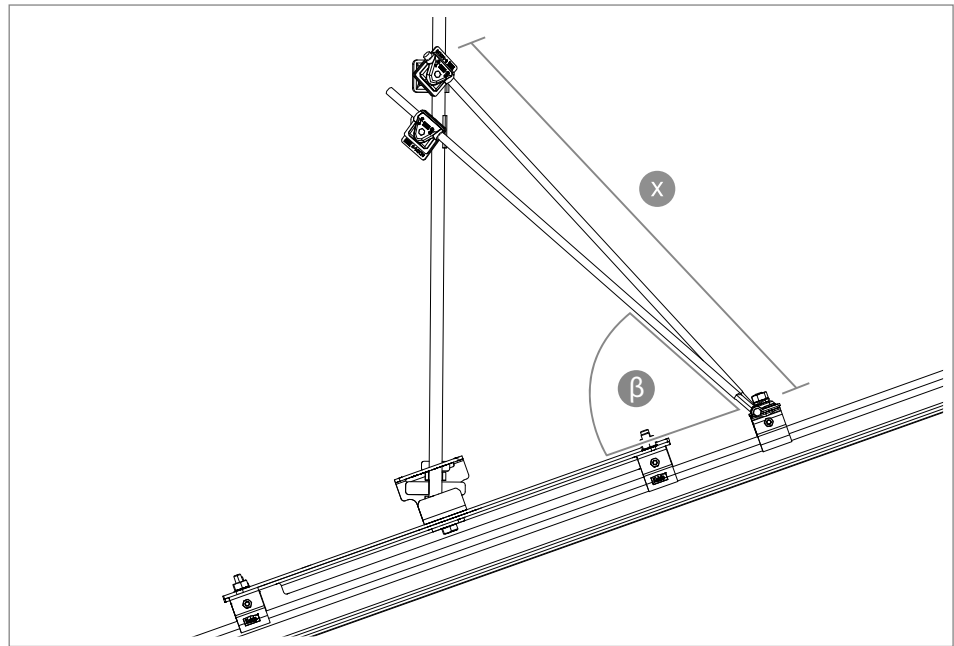

Fig. 13: Angle and length

The length x describes the spacing required on the supporting round conductor between the connection points at the folding clamp and quick connector.

With support on one side, the required length x depends on the diameter \varnothing of the round conductor:

– $\varnothing 8 \text{ mm} \rightarrow x = 400\text{--}500 \text{ mm}$

– $\varnothing 10 \text{ mm} \rightarrow x = 400\text{--}600 \text{ mm}$

The angle β between the round conductor and metal roof must be between 30° and 55° .

With support on two sides, there are no specifications for angle and length, as the air-termination rod is stabilised by tension.

10.4 Mounting the support

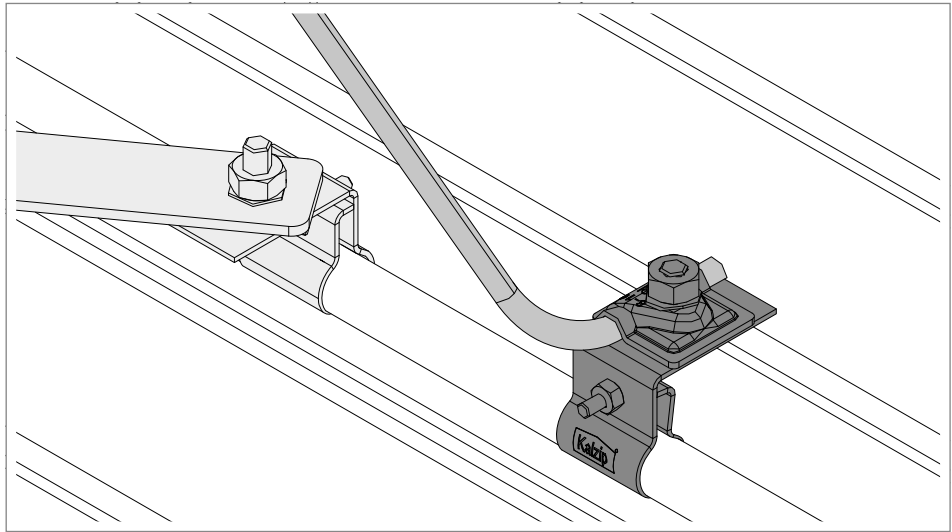

Fig. 14: Fastening the support to the roof

1. Place the folding clamp on the seam of the metal roof on which the air-termination rod fastening is also fastened.
2. Tighten the hexagonal nut M6 on the side of the folding clamp to fasten the folding clamp.
3. Tighten the hexagonal nut M10 on the top side of the folding clamp to fasten the round conductor.

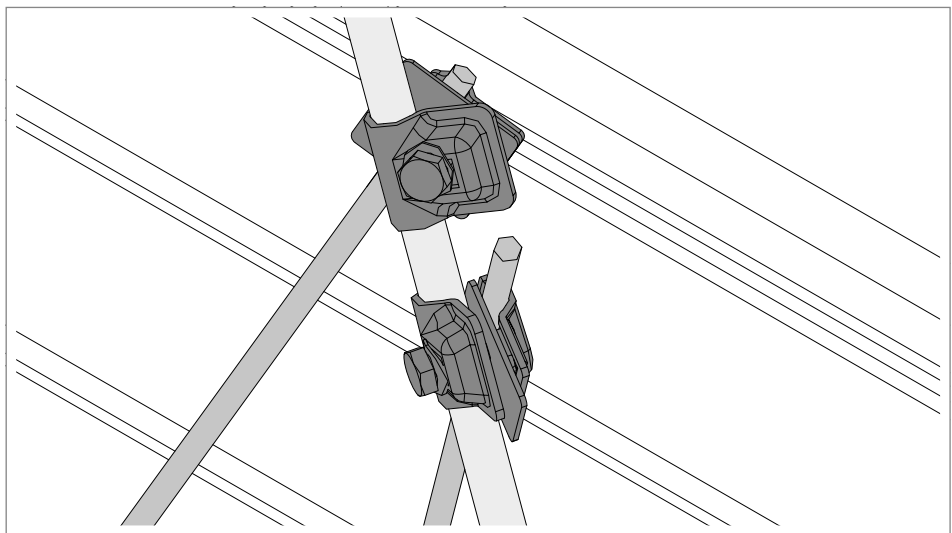

Fig. 15: Fastening the support to the air-termination rod

Note!

Position the fastening points of the quick connector on the air-termination rod as close together as possible.

4. Tighten the bolt M10x30 on the Vario quick connector to fasten the round conductor to the air-termination rod with the Vario quick connector.

11 Maintaining the air-termination rod fastening

Check the air-termination rod fastening as part of the testing of the entire lightning protection system according to DIN EN 62305-3 (IEC 62305-3 and DIN EN 62305-3, Supplementary Sheet 3).

12 Disassembling the air-termination rod fastening

Dismantling of all the elements takes place in the reverse order to mounting.

13 Disposing of the air-termination rod fastening

Comply with the local waste disposal regulations.

- Air-termination rod and air-termination rod fastening: As scrap metal
- Packaging: As plastic or cardboard

14 Technical data

	F-FIX-MD (Item no. 5403336)	F-FIX-MD+ (Item no. 5403337)
Weight	2.52 kg	3.06 kg
Seam spacing	200–560 mm	200–537 mm
Angle of inclination	38°	38°
Material	Stainless steel, rustproof	Stainless steel, rustproof

Tab. 4: Technical data

OBO Bettermann Holding GmbH & Co. KG

P.O. Box 1120
58694 Menden
GERMANY

Technical Office

Tel.: +49 (0)2373 89-1300

technical-office@obo.de

www.obo-bettermann.com

Date 02/2026

251002.02

Building Connections

